

DSP600 L & N Type Series

Distribution Surge Protector

Type 1/2/3 (Test Class I/II/III)

Single & Three Phase Surge Arresters



Ideal for industrial, commercial and domestic applications, the Distribution Surge Protector 600 Series provides an economic means of preventing damage to electrical distribution systems from mainsborne transient voltages. These transients may occur as the result of nearby lightning strikes or surges derived from the switching of inductive or capacitive loads.

The DSP600 'L' and 'N' types should be installed at the point of cable entry to a building and at the distribution point for each floor of a multi-storey building containing sensitive electrical/electronic equipment.

They are normally used as part of a totally integrated surge protection system and as such should be considered as the first line of defence. Local distribution panels and equipment connected 'downstream' should also be protected in order to achieve a systematic and co-ordinated approach to surge protection.

They provide suppression from mainsborne voltage spikes and surges that can occur between phases, phase to neutral, phase to earth and neutral to earth, thus ensuring protection in all modes. This protection is achieved by using carefully matched high energy absorbing elements.

Units feature high surge current handling capability which operates in two stages to ensure continuity of transient suppression. The **DSP600 'N'** type is provided with an on-board system of protection status monitoring Light Emitting Diode's (LED's), while the **DSP600 'L'** type is supplied with a remote monitoring unit, which allows the unit to be installed in areas that are inaccessible for regular inspection.

Under normal conditions both types will automatically reset after clamping smaller, more commonly occurring surges, and a green LED indicates that full protection is present. However, should a surge current, in excess of 30kA, appear on the line it will be clamped by the unit but the first protection stage may possibly suffer damage and fail safe.

In this instance the red LED will be illuminated in addition to the green and although the system will still be adequately protected, the unit should be replaced before a further large surge can remove the second protection stage. There is no protection present when only the red LED is illuminated, although unprotected power is still supplied

Both the DSP600 'N' and 'L' types are supplied with a site fault condition indicator. Should the light on this indicator flash or be permanently illuminated at anytime, it is to warn of a high voltage between neutral and earth lines and therefore potentially hazardous site conditions. The DSP600 'N' and 'L' types are supplied with a remote signalling facility where volt free terminals (which can be connected as either normally open or normally closed), open or close when the first protection stage is lost, (Red and Green LEDs on), and these can be used to activate a remote indicator such as a lamp or an audible alarm. The switching contacts are completely isolated from the supply and may be used for AC mains voltage 230V RMS 200mA or 30V DC 2 Amp loads.



DSP600 'N' - Single Phase



DSP600 'N' - Three Phase



DSP600 'L' - Three Phase

Quality Assurance:

Approved to BS EN ISO 9001

Revision: vPD4, 24/03/17
Information subject to change without notice.

All of the above information, including drawings, illustrations and graphic designs, reflects our present understanding and is to the best of our knowledge and belief correct and reliable. Users, however, should independently evaluate the suitability of each product for the desired application.

PD Devices Ltd • Unit 1-2 • Old Station Yard • South Brent • Devon • TQ10 9AL • United Kingdom

Tel +44 (0)1364 649 248 • E-mail info@pddevices.co.uk • Website www.pddevices.co.uk



DSP600 L & N Type Series

Distribution Surge Protector

Type 1/2/3 (Test Class I/II/III)

Single & Three Phase Surge Arresters



Features:

- Maximum surge current rating of 40kA far exceeds the 10kA requirements of BS6651: 1999 Annex C, to provide long life, and low maintenance.
- Meets the requirements of BS EN62305-4:2006 (which replaced BS6651:1999 Annex C in August 2008) and BS EN61643-11/12 - Type II, Class II
- Tested to IEEE C62.41
- BS6651:1999 Annex C location category C
- Low “let through” voltage of 600 volts.
- Two stage (redundant) protection, with pre-failure indication.
- Full protection status indication, with remote signalling.
- Remote Monitoring Unit model (‘L’ type) allows the unit to be installed in areas that are inaccessible for regular inspection.
- Site fault condition indicator.
- Remote Monitoring Unit is provided with a 1 metre cable and appropriate plug and socket connectors (other lengths are available on request).
- Easy installation and field serviceability.
- Rugged construction (steel enclosure).
- Compact size and small footprint.

Applications

- Front end of building protection.
- Individual protection of critical and costly equipment such as computer systems.
- Sub-distribution panel protection.

Installation:

Designed to be easily installed alongside the incoming electrical supply panel or at the sub distribution board of a multi-storey block, the 600 Series is connected in parallel with the supply, thus eliminating complicated by-pass wiring associated with series suppressors. Connected in this manner the 600 Series carries only the current associated with the transient being discharged.

The 600 Series should be installed as close as possible to the Bus Bars/Equipment being protected, with as large a conductor as possible (16mm² max). The connecting wires should be routed, avoiding looping, and secured together with ties. The Distribution Surge Protector must be connected in parallel to the supply via an isolating switch if the mains supply cannot be switched off for 600 Series replacement.

If RCDs are used on the supply the 600 Series must be fitted in front of such devices to avoid nuisance tripping. Provision should be made for safe replacement of the 600 Series should this become necessary. The DSP600 ‘N’ type may be installed in an existing cubicle with viewing window or in a housing with transparent cover, available separately, whereas the DSP600 ‘L’ type supplied with remote monitoring unit is ideal for installations that do not allow for regular inspection of the unit itself.

Fusing:

The 600 Series is suitable for direct connection to a line rated up to 100A (6mm² min. connecting cables), but can be connected to lines of higher rating by the provision of series fuses rated 50A min – 100A max (BS HD 60269-2:2010, BS 88-2:2010). If MCBs are used in place of fuses they should be of type C.

Maintenance:

The 600 Series requires no maintenance but the LED’s should be checked at regular intervals to ensure that full protection is present. The remote signalling facility of the ‘L’ and ‘N’ types is provided for remote indication of the units protection status, for instance in control rooms, mimic panels etc.

Revision: vPD4, 24/03/17
Information subject to change without notice.

All of the above information, including drawings, illustrations and graphic designs, reflects our present understanding and is to the best of our knowledge and belief correct and reliable. Users, however, should independently evaluate the suitability of each product for the desired application.





DSP600 L & N Type Series

Distribution Surge Protector

Type 1/2/3 (Test Class I/II/III)

Single & Three Phase Surge Arresters



Specification	Single Phase 	Three Phase 
Voltage rating (Nominal)	230V rms	400V rms
Operating voltage range	200 - 300V rms	L-N 200 - 300 V rms L-L 350 - 500 V rms
Maximum current rating	Unlimited (Parallel Connection)	Unlimited (Parallel Connection)
Maximum surge current handling (8/20 μs)	40kA	40kA per phase
Response time	<10 ns	<10 ns
Power consumption (nominal)	18mA	18mA per phase
Leakage current to earth	200μA	600μA
Terminals	16mm ² max - Line, Neutral, Earth 2.5mm ² max - Remote Signalling	16mm ² max - Line, Neutral, Earth 2.5mm ² max - Remote Signalling
Remote signalling terminals	Rated at 230V rms 0.2 Amp or 30V DC 2 Amp	Rated at 230V rms 0.2 Amp or 30V DC 2 Amp
Remote Monitoring Unit Connectors ('L' type only)	N/A	15 Way 'D'
Operating temperature	-40° to +70° Celcius	-40° to +70° Celcius
Light emitting diodes status indication	Green - Full Protection Red & Green - Reduced Protection Red - No Protection	Green - Full Protection Red & Green - Reduced Protection Red - No Protection
Site Fault Condition Indicator	Red Lit / Flashing	Red Lit / Flashing
Case	Steel - Epoxy Paint	Steel - Epoxy Paint
Type according to BS EN 61643-11	2	2
Dimensions (in mm)		
L	176	176
W	42	110
D	72	72
Weight (in grams)	650	1110
Part Codes:	DSP1N/600	DSP3L/600 DSP3N/600

Revision: vPD4, 24/03/17

Information subject to change without notice.

All of the above information, including drawings, illustrations and graphic designs, reflects our present understanding and is to the best of our knowledge and belief correct and reliable. Users, however, should independently evaluate the suitability of each product for the desired application.

PD Devices Ltd • Unit 1-2 • Old Station Yard • South Brent • Devon • TQ10 9AL • United Kingdom

Tel +44 (0)1364 649 248 • E-mail info@pddevices.co.uk • Website www.pddevices.co.uk



DSP600 L & N Type Series

Distribution Surge Protector

Type 1/2/3 (Test Class I/II/III)

Single & Three Phase Surge Arresters



Surge Test:

The 600 Series complies with, or is tested to, the requirements of: BS EN62305-4:2006, BS EN61643-11/12, IEEE C62.41, UL1449.1985, BS6651:1999 Annex C. The test waveform – 6kV 1.2/50µs O/C, 3kA 8/20µs S/C – applied to the 600 series gives the resultant let through voltage. **See tabulation below.**

(The 'let through voltage' will vary due to the parasitic inductance of the associated mains cable.)
Values given are at protector terminals.

Let Through Voltage	
Test simulating the effects of lightning and switching transients	Phase/Neutral Phase/Earth
6kV 1.2/50µs open circuit voltage; 3kA 8/20µs short circuit current	600V
4kV 1.2/50µs open circuit voltage; 2kA 8/20µs short circuit current	560V
5kA 8/20µs	670V
6kV 0.5µs 100kHz ring wave, 500A	520V

DSP1N/600 Dimensions in mm

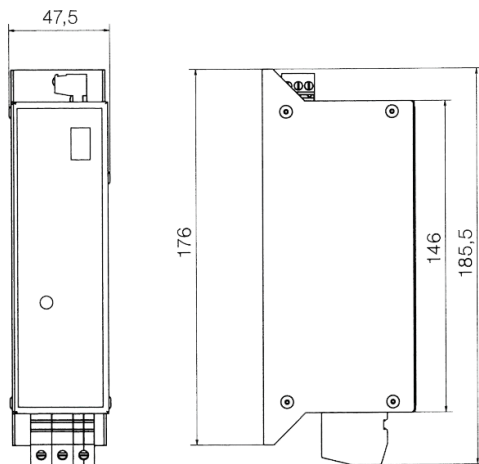

DSP3L/600 & DSP3N/600 Dimensions in mm

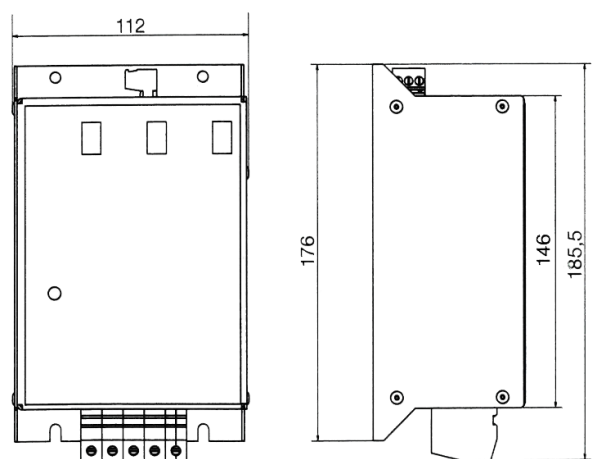

600 Series Optional Enclosure	
Optional Enclosure Case	Polycarbonate
IP Rating (before installation)	56
Dimensions (mm)	
L	245
W	195
D	100
Part Code	2IP-7-0244

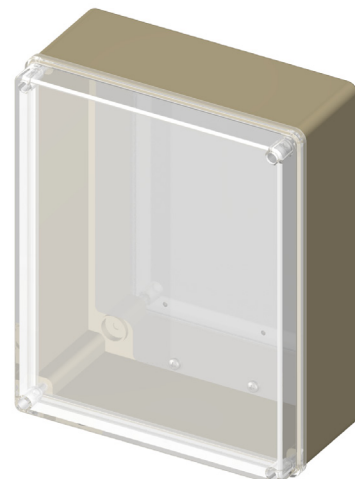

Revision: vPD4, 24/03/17
Information subject to change without notice.

All of the above information, including drawings, illustrations and graphic designs, reflects our present understanding and is to the best of our knowledge and belief correct and reliable. Users, however, should independently evaluate the suitability of each product for the desired application.

