

ZOMM Series

(Zinc Oxide Military Modules)

ZOMM 221/ (XXX) /1/30



PD Devices Ltd manufacture a wide range of products to protect against the effects of high altitude detonation of Nuclear devices. The result of such an event is the generation of Electromagnetic Pulses which will induce a high voltage transient in exposed conductors.

The EMP can affect several thousands of square kilometres, with a magnitude of tens of kilovolts.

This could result in serious damage to insulation, cause breakdown of semiconductors and the consequent malfunction of critical equipment.

Most notable would be the failure of Energy Power Supply and Communications Systems. We offer products to satisfy protection for most applications



Product Image Coming Soon

Specification	
No. of channels	30
50 Shot (4/20µs) Repetitive Duty	1500A
Response Time	<10ns
Continuous Current per Channel	10A
Max. (8/20µs) Current per Channel	8000A
Leakage Current per Channel at Rated Voltage, DC	<200µA
Through Inductance	<10µH
Volts Drop	Negligible
Terminations	3mm Dia Brass
Bushes	PTFE
Earth Connection	To Base Plate
Recommended Torque per M4 Terminal	1.0Nm (Ensure terminal does not rotate)

Explanation of Order Code

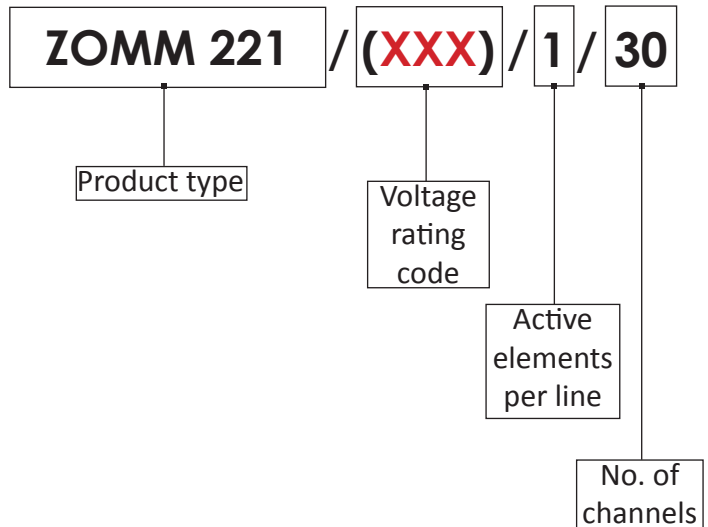

PD Devices reserves the right to amend specifications in line with product development.

(XXX)		400	401	502	503	504	505	508	509	510
Continuous Operating Voltage	AC (rms)	50	60	95	110	120	135	220	250	280
Energy per channel (Joules)	(10/1000µs)	55	65	95	100	110	130	210	240	250
Max. Peak Clamping Volts @	100A (8/20µs)	170	200	250	310	340	390	650	700	820

Revision: vPD2, 22/05/18
Information subject to change without notice.

All of the above information, including drawings, illustrations and graphic designs, reflects our present understanding and is to the best of our knowledge and belief correct and reliable. Users, however, should independently evaluate the suitability of each product for the desired application.



ZOMM Series

(Zinc Oxide Military Modules)

ZOMM 221/ (XXX) /1/30



ZOMM 221/(XXX)/1/30 Diagram in mm

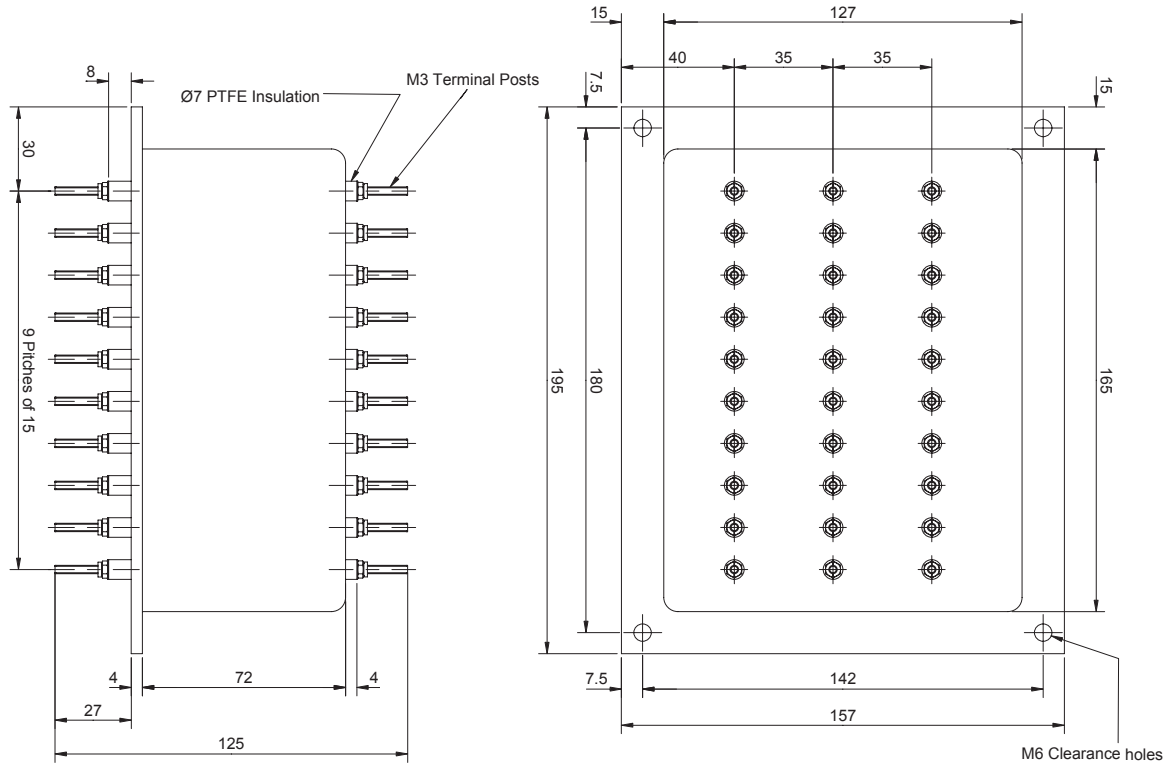

This ZOMM Application is recommended for Zone 0,1 & 2

ZONE 0 (EXTERNAL- HOSTILE)

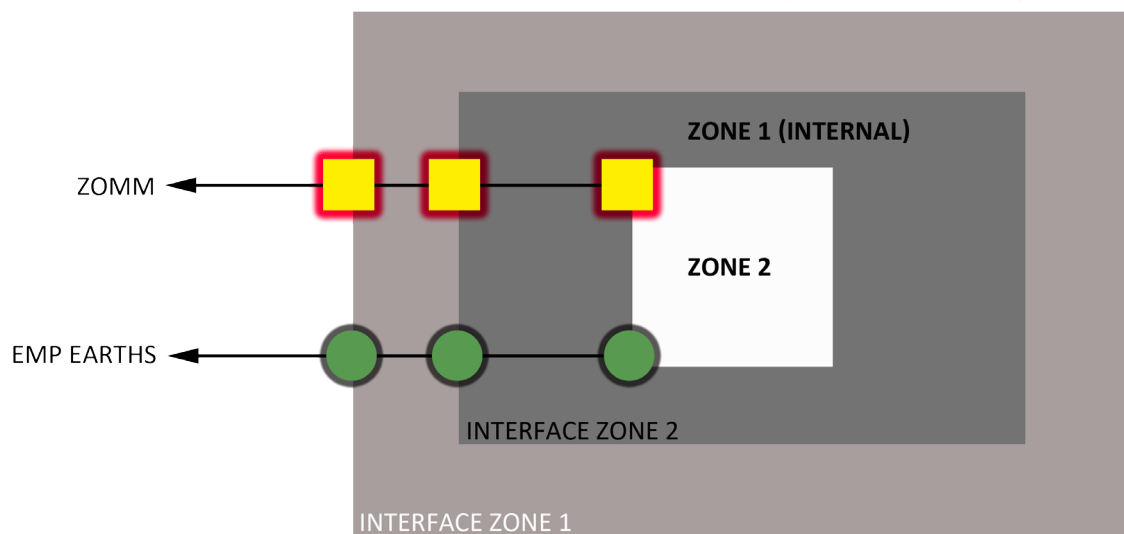

INTERFACE ZONE 0

Revision: vPD2, 22/05/18
Information subject to change without notice.

All of the above information, including drawings, illustrations and graphic designs, reflects our present understanding and is to the best of our knowledge and belief correct and reliable. Users, however, should independently evaluate the suitability of each product for the desired application.

